

2 Series - Micro Diaphragm Vacuum Pump

Model:BD-02V 3L

Pneumatic Data	
Maximum Vacuum (Negative Pressure)	-65 kpa (-488mmHg/-0.650Mpa)
Maximum Flow(@0 kPa)	3 L/min
Electrical Data	
Motor Type	DC Brush Motor
Rated Voltage	6V
Rated Current	<0.2A
Noise From 50cm	63 dB
Working Mode	Intermittent
Life Time	500 hours
Other Data	
Inlet/Outlet Diameter	Φ4.0 mm/Φ2.2 mm
Dimensions	55x40x24.3 mm
Weight	71 g
Pump Head/Body Material	Nylon
Diaphragm And Valve Material	EPDM
Operating Environment Temperature	5-45 °C



Features

- Miniature diaphragm vacuum pump, small size , maintenance-free
- Precise production, high flow, high vacuum
- Brush motor, operation life of more than 500 hours.

Dimensional Outline Drawing (Unit:mm)

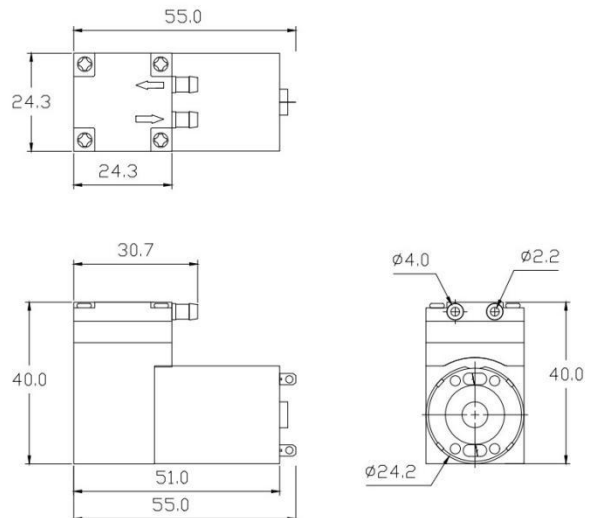

Accessories Optional

Check Valve, Silicone Shock Bracket, Muffler



Usage and Attention

1. Red point or red wire on motor marked as Positive pole; Black wire on motor marked as negative pole.
2. Expected lifetime: approx 500 hours with continuous running under condition of rated voltage and normal temperature (25°C), it is recommended to work continuously for no more than 30 minutes each time.
3. Please do not exceed the maximum specifications required , Otherwise we don't guarantee the product.
4. This product does not guarantee lifetime and defective products due to get into of dust, water droplets, bugs.
5. Impurities in prohibited from entering the motor and water droplets, In order to avoid to cause product performance unstable and damage products.

2 Series - Micro Diaphragm Vacuum Pump

Model:BD-02VB 1L

Pneumatic Data	
Maximum Vacuum (Negative Pressure)	-30 kPa (-225mmHg/-0.030Mpa)
Maximum Flow(@0 kPa)	1 L/min
Electrical Data	
Motor Type	DC Brushless Motor
Rated Voltage	6V
Rated Current	<0.2A
Noise From 50cm	63 dB
Working Mode	Continuous or Intermittent
Life Time	3000 hours
Other Data	
Inlet/Outlet Diameter	Φ4.0 mm/Φ2.2 mm
Dimensions	53x40x24.3 mm
Weight	73 g
Pump Head/Body Material	Nylon
Diaphragm And Valve Material	EPDM
Operating Environment Temperature	5-45 °C



Features

- Miniature diaphragm vacuum pump, small size , maintenance-free
- Precise production, high flow, high vacuum
- Brushless motor, operation life of more than 3000 hours.

Dimensional Outline Drawing (Unit:mm)

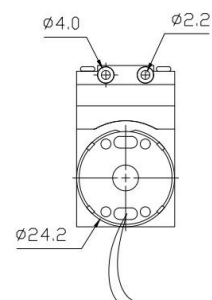
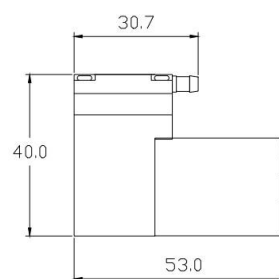
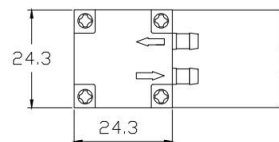

Accessories Optional

Check Valve, Silicone Shock Bracket, Muffler



Usage and Attention

1. Red point or red wire on motor marked as Positive pole; Black wire on motor marked as negative pole.
2. Expected lifetime: approx 3000 hours with continuous running under condition of rated voltage and normal temperature (25°C), it is recommended to work continuously for no more than 2 hours each time.
3. Please do not exceed the maximum specifications required , Otherwise we don't guarantee the product.
4. This product does not guarantee lifetime and defective products due to get into of dust, water droplets, bugs.
5. Impurities in prohibited from entering the motor and water droplets, In order to avoid to cause product performance unstable and damage products.

2 Series - Micro Diaphragm Vacuum Pump

Model:BD-02VB 1.5L

Pneumatic Data	
Maximum Vacuum (Negative Pressure)	-50 kpa (-375mmHg/-0.050Mpa)
Maximum Flow(@0 kPa)	1.5 L/min
Electrical Data	
Motor Type	DC Brushless Motor
Rated Voltage	6V
Rated Current	<0.2A
Noise From 50cm	63 dB
Working Mode	Continuous or Intermittent
Life Time	3000 hours
Other Data	
Inlet/Outlet Diameter	Φ4.0 mm/Φ2.2 mm
Dimensions	53x40x24.3 mm
Weight	73 g
Pump Head/Body Material	Nylon
Diaphragm And Valve Material	EPDM
Operating Environment Temperature	5-45℃



Features

- Miniature diaphragm vacuum pump, small size , maintenance-free
- Precise production, high flow, high vacuum
- Brushless motor, operation life of more than 3000 hours.

Dimensional Outline Drawing (Unit:mm)

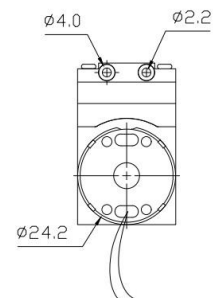
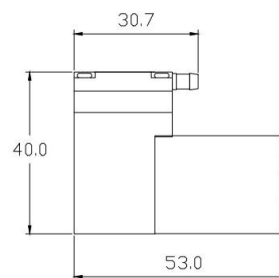
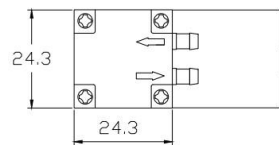

Accessories Optional

Check Valve, Silicone Shock Bracket, Muffler



Usage and Attention

1. Red point or red wire on motor marked as Positive pole; Black wire on motor marked as negative pole.
2. Expected lifetime: approx 3000 hours with continuous running under condition of rated voltage and normal temperature (25℃), it is recommended to work continuously for no more than 2 hours each time.
3. Please do not exceed the maximum specifications required , Otherwise we don't guarantee the product.
4. This product does not guarantee lifetime and defective products due to get into of dust, water droplets, bugs.
5. Impurities in prohibited from entering the motor and water droplets, In order to avoid to cause product performance unstable and damage products.

2 Series - Micro Diaphragm Vacuum Pump

Model:BD-02VB 3L

Pneumatic Data	
Maximum Vacuum (Negative Pressure)	-65 kpa (-488mmHg/-0.650Mpa)
Maximum Flow(@0 kPa)	3 L/min
Electrical Data	
Motor Type	DC Brushless Motor
Rated Voltage	6V
Rated Current	<0.2A
Noise From 50cm	63 dB
Working Mode	Continuous or Intermittent
Life Time	3000 hours
Other Data	
Inlet/Outlet Diameter	Φ4.0 mm/Φ2.2 mm
Dimensions	53x40x24.3 mm
Weight	73 g
Pump Head/Body Material	Nylon
Diaphragm And Valve Material	EPDM
Operating Environment Temperature	5-45℃



Features

- Miniature diaphragm vacuum pump, small size , maintenance-free
- Precise production, high flow, high vacuum
- Brushless motor, operation life of more than 3000 hours.

Dimensional Outline Drawing (Unit:mm)

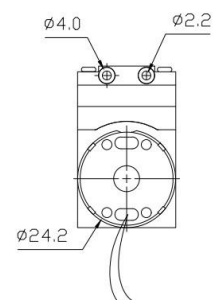
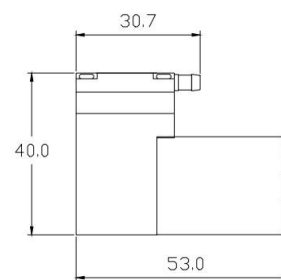
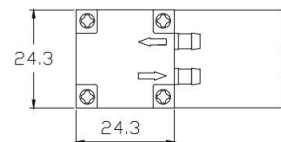

Accessories Optional

Check Valve, Silicone Shock Bracket, Muffler



Usage and Attention

1. Red point or red wire on motor marked as Positive pole; Black wire on motor marked as negative pole.
2. Expected lifetime: approx 3000 hours with continuous running under condition of rated voltage and normal temperature (25℃), it is recommended to work continuously for no more than 2 hours each time.
3. Please do not exceed the maximum specifications required , Otherwise we don't guarantee the product.
4. This product does not guarantee lifetime and defective products due to get into of dust, water droplets, bugs.
5. Impurities in prohibited from entering the motor and water droplets, In order to avoid to cause product performance unstable and damage products.